

Portable Compressors

Mobilair™ M27 Utility



Versatile

The Mobilair™ M27 Utility rotary screw compressor is designed for transverse mounting on service vehicles. It delivers 92 cfm at 100 psig and is ideal for a wide range of applications including sand/shot blasting, demolition, fence post driving, irrigation system maintenance and monument engraving.

Efficient and Reliable

A heavy-duty 3-cylinder Kubota diesel engine direct coupled to our energy saving Sigma Profile airend produces more air per gallon of fuel. The high capacity cold start battery ensures reliable operation even under extreme

conditions. The M27 Utility's rugged, powder-coated steel cabinet is mounted on a galvanized frame and built to protect the machine from dirt, water, and other contaminants. The engine and compressor have separate inlet filters with maintenance indicators. This protection, combined with a high efficiency cooling system, allows the unit to operate in ambient temperatures up to 120°F.

Convenient

The M27 Utility is very compact. It has both long and short side forklift slots as well as a single-point lifting hook for easy mounting/dismounting. The two ¾" hose connections and controls

are curbside for safety. The instrument panel features a full range of indicators, including hour meter, air pressure, fuel, and discharge temperature gauges. The canopy provides full access to the tool box and maintenance points. Sound and vibration isolation ensure smooth, quiet running for work crews and neighbors. Another important feature is the large 10.6 gallon fuel tank that provides extended operation - up to 8 full hours!

Standard Features:

- Sigma Profile™ rotary screw airend produces more air per gallon of fuel
- Meets Tier 4 EPA emissions standards
- Energy efficient direct drive
- Large fuel tank for 8 hours of continuous operation
- Powder coated steel enclosure with soundproofing and vibration isolation
- High capacity cold start battery
- Patented anti-frost control prevents freeze-up
- Highly efficient cooling system

Options:

- 5 year warranty

Technical Specifications

COMPRESSOR			DIESEL ENGINE				PACKAGE			DIMENSIONS
Model	Free Air Delivery (cfm)	Working Pressure (psig)	Make	Power @ Full Load (hp)	Full Load Speed (rpm)	Off Load Running Speed (rpm)	Fuel Tank Capacity (gal)	Weight (lb.)	Outlets	L x W x H (in.)
M27 Utility	92	100	Kubota D1105-B	21	2850	2100	10.6	1267	2 x 3/4"	80 x 39 1/4 x 42 1/4

Sound level maximum is 76 db(A) at 23 feet.

Specifications are subject to change without notice.

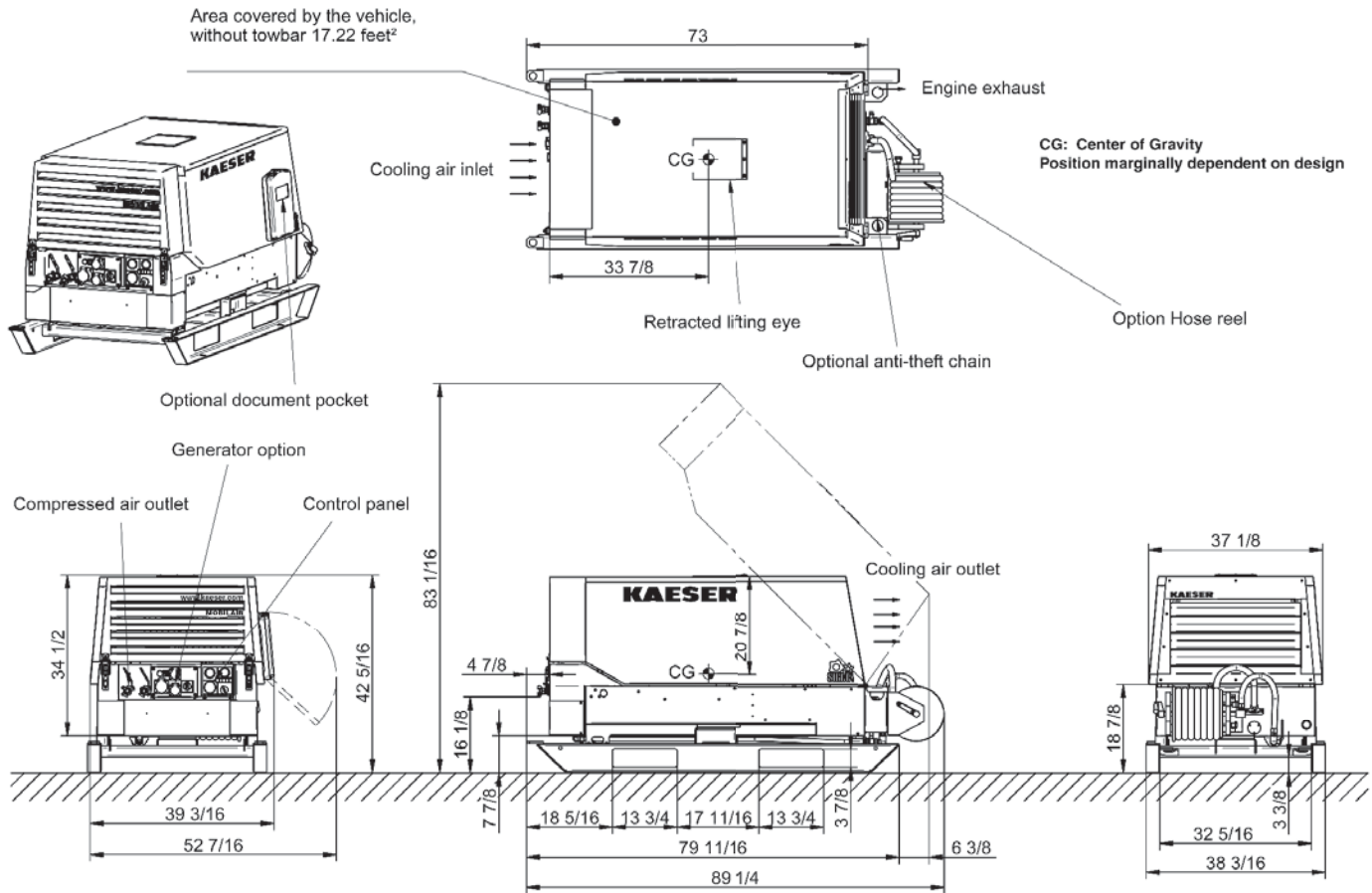

KAESER COMPRESSORS®

Built for a lifetime.



www.kaeser.com

Kaeser Compressors, Inc.
511 Sigma Drive
Fredericksburg, VA 22408 USA
Telephone: 540-898-5500
Toll Free: 800-777-7873
info.usa@kaeser.com

Kaeser Compressors Canada Inc.
3760 La Verendrye Street
Boisbriand, QC J7H 1R5 CANADA
Telephone: (450) 971-1414
Toll free: (800) 477-1416
info.canada@kaeser.com

Kaeser Compresores de México S de RL de CV
Calle 2 #123
Parque Industrial Jurídica
76100 Querétaro, Qro.
Telephone: 01 (442) 218 64 48
sales.mexico@kaeser.com

Kaeser Compresores de Guatemala y Cia. Ltda.
Calz. Atanasio Tzul 21-00, zona 12
El Cortijo II, Bodega 501
01012-Guatemala City
Telephone: +502 2412-6000
info.guatemala@kaeser.com

