

KAESER
COMPRESSORS®

Built for a lifetime.



Oil-free Screw Compressors

CSG Series

Capacities from: 142 to 596 cfm

Pressures from: 60 to 160 psig

The next-generation oil-free rotary screw compressor

For greater peace of mind in food and beverage, pharmaceutical, electronics, chemical, laboratories, and other applications with the most stringent air purity needs, the KAESER CSG series delivers more reliably safe and energy efficient compressed air with no compromises. We designed the CSG to minimize all aspects of life-cycle costs, and it is full of features that extend maintenance intervals and service life while reducing energy costs - and all in a 20% smaller footprint that offers maximum flexibility in planning and installation. With the CSG series, KAESER has delivered oil-free that is trouble-free.

Premium air quality

The CSG series features KAESER's unique two-stage airend block with a biocompatible three layer coating that meets FDA standards. This combination of nanoceramics and high-performance polyetheretherketone (PEEK) is more durable and will not wear off like PTFE or other coatings. Other components in the compressed air pathway are also coated or made from food safe materials, and the compressors are 100% silicone free. To remove moisture, CSGs are available with integrated refrigeration or desiccant dryer options.

Significant energy savings

An all new SIGMA PROFILE airend, designed and built by KAESER, in combination with the highest drive motor efficiencies uphold the KAESER reputation for energy efficiency. CSG units boast up to 16% more flow and as much as a 19% improvement in specific performance, with a maximum operating pressure increased to 160 psig. SIGMA FREQUENCY CONTROL (SFC) models leverage the advantages of synchronous reluctance IE5 motors to ensure the highest levels of energy efficiency. On both fixed and variable speed units, a speed-controlled radial fan maintains proper cooling air flow while minimizing power.

Lower service costs

With the CSG, KAESER has upgraded its oil-free compressor design to extend service intervals and eliminate maintenance points to reduce costs while increasing reliability and uptime. Our new inlet valve has an extended service life and the pulsation dampeners are maintenance free. Compressor stages and gear fluid service intervals are 50% longer. Maintenance intervals on the condensate drains are three times longer.

Condition monitoring

With the SIGMA CONTROL 2 and a suite of sensors, the operation of your CSG is constantly supervised. Vibrations, motor winding temperatures, motor bearing temperature, and automatic lubrication, for example, are all tracked by the SIGMA CONTROL 2. Conditions can be easily monitored remotely within your internal systems or remotely as part of a service plan to avoid problems before they create costly repairs or downtime.



Peace of mind

Air quality assured

With our extensive experience in the full range of compressed air applications, KAESER understands the air purity needs and the demanding requirements to ensure consumer safety and minimize risk in production. KAESER's oil-free rotary screw compressors are ideal for compressed air supply in sensitive processes.

From design to component sourcing to manufacture, our CSG oil-free compressors are the result of comprehensive evaluation of your needs. Specifically, this means that KAESER considers the air flow path within our compressors when selecting materials, and great care is taken to ensure that all components are suitable for use in these sensitive production processes.



Residual oil “Class 0” per ISO 8573-1

The risk of potential product contamination by the rotary screw compressor is evaluated and minimized by means of an HACCP analysis. Our diligence is confirmed compliance for residual oil “Class 0” in accordance with ISO 8573-1. CSG compressors are also certified silicone free. Therefore, CSG is ideal for facilities with ISO 22000 Food Safety Management Systems.

Traceable quality

All functionally relevant components in the compressor air end are 100% traceable in terms of material and manufacturing. This creates transparency, particularly in sensitive production processes.



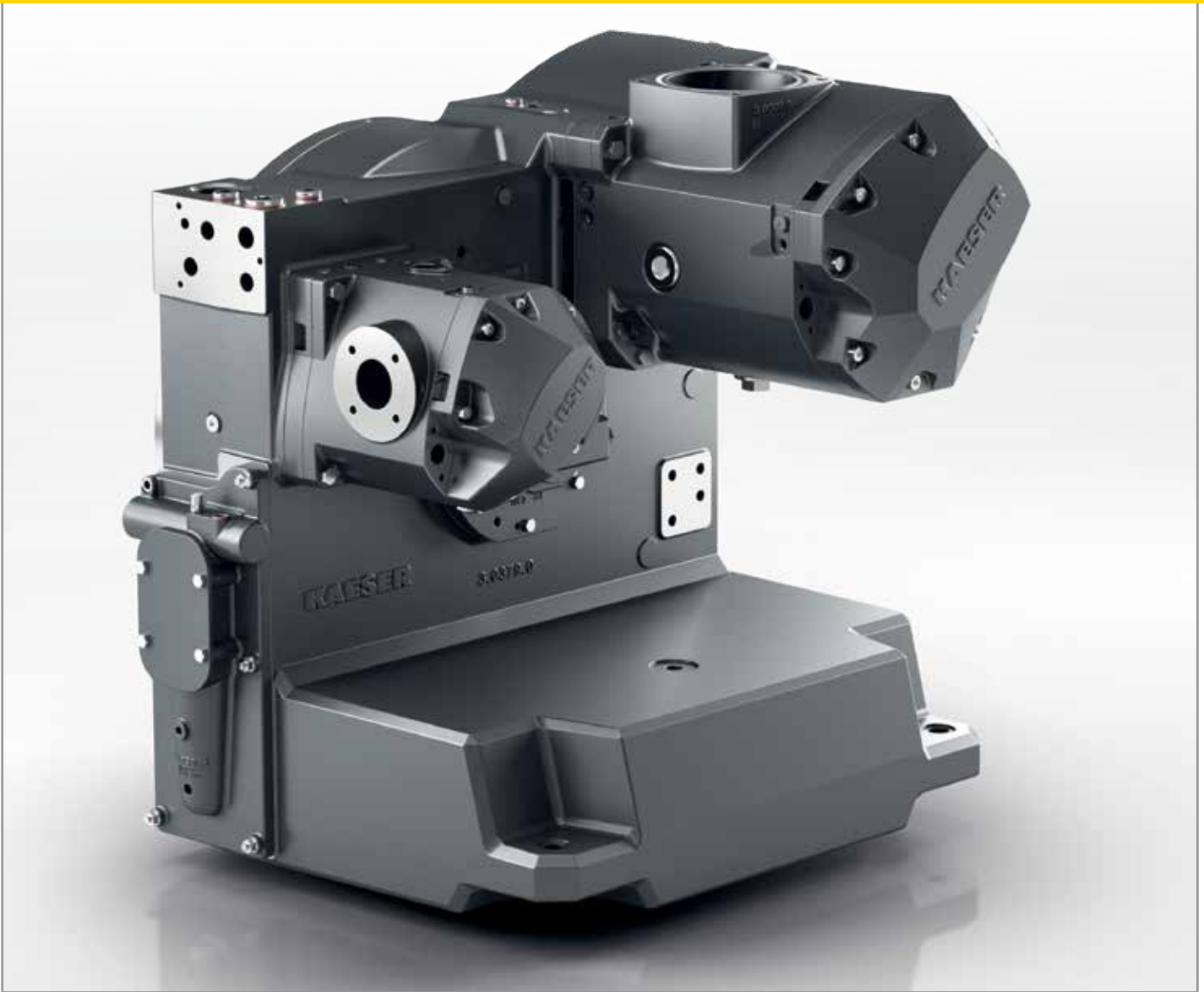

KAESER SIGMA PROFILE

At the heart of every CSG compressor lies premium-quality airends featuring KAESER's SIGMA PROFILE design that combines maximum energy efficiency with sustainable durability.



Food safe coating

The rotors and housings on CSG airends feature a patented triple-layer PEEK and nanoceramic coating. Not only is this exceptionally durable, but also food-safe, as certified by the FDA and EU regulation 1935.

Rotary screw airend with SIGMA PROFILE

Uniquely KAESER

The CSG series represents the latest generation of oil-free technology, combining KAESER's industry leading SIGMA PROFILE rotor design with a new non-wearing coating that offers greater peace of mind in food and beverage, pharmaceutical, electronics, chemical, laboratories, and other applications requiring oil-free air.

Innovative PEEK coating

The CSG's unique coating represents a significant advancement in rotor coating for exceptional durability and long lasting performance. This coating is a combination of nanoceramics and high-performance polyetheretherketone (PEEK), which is double heat-treated and temperature-stable over 750°F. Its outstanding abrasion resistance characteristics make it ideal for use in the food and pharmaceuticals industries. The CSG airend has no PTFE or other wearing coatings that can create contamination or reduce efficiency over time. With CSG, there are no run-in periods or efficiency losses over time.



Easy maintenance

Ease of maintenance was a top priority from the very outset of the CSG development process, with fewer service points and longer service intervals. Features like our innovative casting design reduce the time needed to change gear oil and maximize the service life of fresh oil, thanks to the lower residual oil content during oil changes.



Water jacket cooling

A water jacket cooling system ensures optimal operating temperatures in the first and second compression stages. Efficiency is significantly increased during compression thanks to the maximized cooling surface area. Furthermore, integration of the water lines ensures reliable leak prevention.

Service...

...virtually maintenance-free



Easy-care inlet valve

The pneumatically operated inlet valve is more responsive than typical hydraulic valves and is unaffected by contaminants and condensate. Thanks to its robust mechanics and absence of fluid, service is only required after 18,000 operating hours. The interior coating is suitable for use in the food and pharmaceuticals industries.

Long-life compressor unit

KAESER's oil-free compression rotary screw airend is exceptionally durable with 50% longer service interval. Preventative replacement is not required. The standard-equipped vibration monitoring ensures reliable operation.



Image: CSG 150 W SFC i.HOC

...excellent accessibility



Pulsation dampeners

Thanks to an effective combination of a chamber silencer and Venturi nozzle, KAESER's newly developed, efficient, broadband pulsation dampeners minimize unwanted noise, vibration and pressure losses. The fiber-free design eliminates a point of maintenance and possible source of particle contamination. The interior coating is suitable for use in the food and pharmaceutical industries.



Increased motor life

CSG drive motors are selected for longevity and are protected by automatic bearing lubrication. Both the motor bearing and winding temperatures are monitored by the onboard SIGMA CONTROL 2 and may be remotely monitored as well.



Image: CSG 150 W SFC i.HOC



Water jacket cooling

Our innovative water jacket cooling design increases compression efficiency 2% and also reduces gearbox oil temperatures to extend gear oil life by 50% (to 18,000 hours).

Variable cooling air flow rate

A speed controlled fan regulates cooling air flow based on actual conditions. This saves power and adjusts outlet temperatures and enables optimal adjustment to the corresponding load situation and cooling air temperature.



CSG series

Air cooling

Dependable performance —
even under extreme conditions

The benefits:

Variable cooling air flow - enhances efficiency

Water jacket cooling - enhances efficiency, ensures dependable
operation at high ambient temperatures



Continuous operation at 115°F

Air-cooled CSG machines operate dependably in ambient temperatures up to 115°F, thanks to their energy-efficient radial fan. This ensures dependable performance even under extreme conditions.

CSG series

Water cooling

Compact energy-savers

The benefits:

Variable cooling water flow - enhances efficiency

Increased cooling surface area - enhances efficiency, ensures low discharge temperatures



Parallel flow

Flow through all coolers in CSG systems is implemented in parallel to assure optimal operating temperatures. The same respective inlet temperature ensures significantly increased overall efficiency.

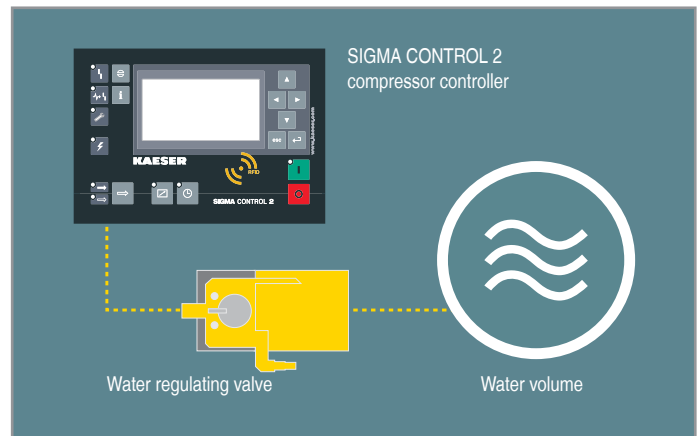

Optimum cooling water flow

Water-cooled CSG compressors are equipped with water regulating valves downstream from each heat exchanger. This way, each consumer receives the optimal amount of water, resulting in an economical and more sustainable use of cooling water. During standby mode, when the compressor does not require cooling, the water flow is stopped and waste is avoided.

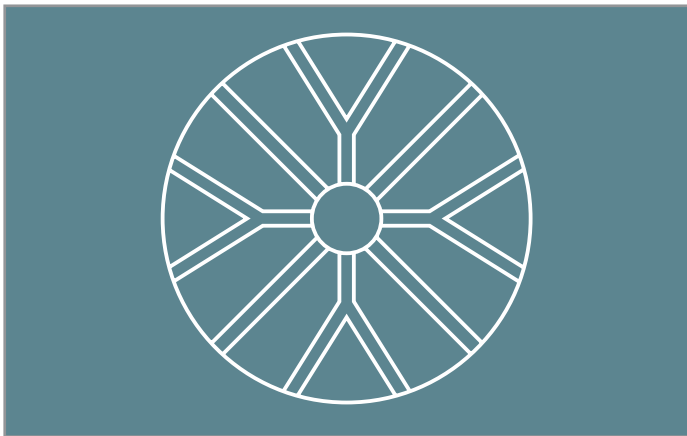

Innovative snowflake profile

CSG coolers features the innovative snowflake profile, which increases heat transfer surface area by 46%. In addition to better cooling efficiency, it reduces heat exchanger length and overall compressor footprint.



Optimized cooler flow

The flow-optimized air inlet and outlet ensure significantly reduced pressure loss. In addition, the cooler air flow path is made of stainless steel.

SIGMA CONTROL 2 integrated compressor controller

SIGMA CONTROL 2

The integrated SIGMA CONTROL 2 controller coordinates and ensures efficient, reliable machine operation, and enables critical communication in systems with multiple compressors. It monitors conditions at all internal sensors including vibrations and various temperatures. Status messages and alerts are shown on the controller display, and can be simply and conveniently monitored from any desk with a PC thanks to the integrated web server. A multitude of communications ports are available, including the option of connecting the machine to a central control system.



Efficient thermal management

For durable compressor operation, well-balanced thermal management of the compressor is required. SIGMA CONTROL 2 processes the necessary sensor and actuator information in order to regulate the cooling performance as needed. Fan speed is varied on air-cooled compressors, while on water-cooled compressors, the cooling water volume is individually adjusted for each heat exchanger.



Dependable condensate separation

Thanks to its flow-optimized design, the efficient axial centrifugal separator reliably separates accumulating condensate downstream from the air coolers - with minimal pressure loss. The integrated SIGMA CONTROL 2 compressor controller ensures dependable condensate drainage.

Integrated refrigerated dryer option

All air-cooled CSG (both fixed and variable speed) are available with integrated refrigerated dryers for reliable and economical moisture removal for protection of products and pneumatic equipment in many applications. T model dryers need little maintenance and all refrigeration dryer components are easily accessible via the service door on the front of the unit.



Energy-saving drying

The generously dimensioned aluminum heat exchanger has a pressure drop below 1.5 psig, and combined with a new energy-saving scroll refrigerant compressor we achieved 7% overall power reduction in the dryer. CSG T dryers use R-513A refrigerant, which has a very low GWP value and allows for 30% less refrigerant.



Integrated Heat of Compression dryer option

For applications requiring lower dew points than a refrigerated dryer can reach, KAESER's patented Integrated Heat of Compression (i.HOC) dryer offers sub-freezing pressure dew points without additional energy consumption. By using heat of compression in a full-flow regeneration method, these dryers deliver reliable pressure dew points without consuming power to heat the regeneration air.

The benefits:

- Available on both air and water-cooled CSG models
- Dependable sub-zero pressure dew points even in high temperature conditions
- Pressure dew point sensor for monitoring drying quality integrated as standard
- Pressure dew point stability even at low load without need for a partial load compensator
- Available with pressure dew point control if required

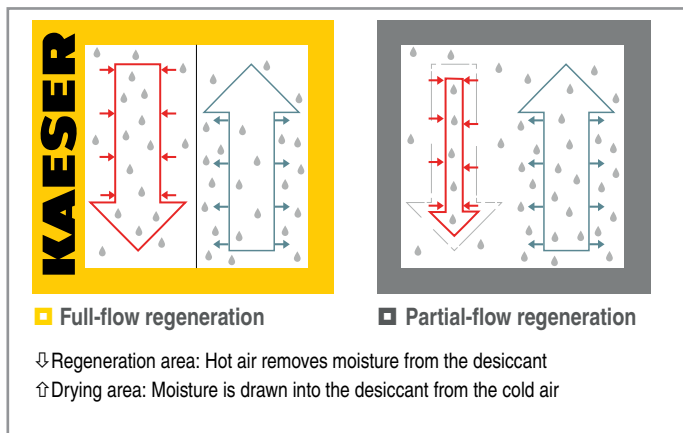

Full-flow regeneration

The Integrated Heat of Compression dryer (i.HOC) system uses the heat of compression from the second compression stage to provide heat for full-flow regeneration with no additional energy cost.

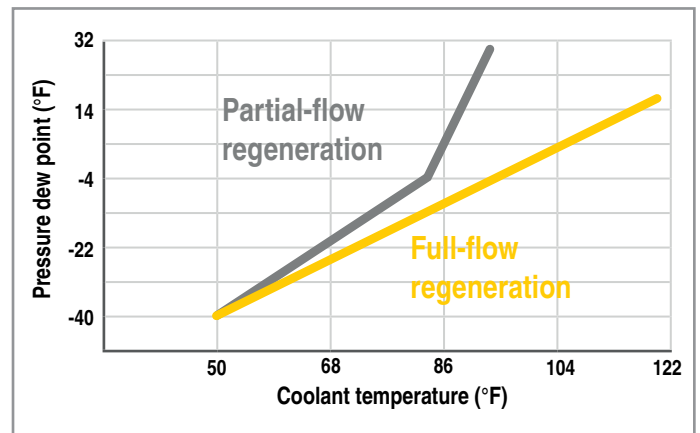

Drying even near the limit

Full-flow regeneration is especially useful during higher temperature operation. KAESER i.HOC dryers achieve outstanding drying results, even without additional electrical heating of the regeneration air.



Reliable dew points

The i.HOC rotation dryer's intelligent control ensures pressure dew point stability even with fluctuating flow rates and at partial compressor load. When commissioned, the target pressure dew point is reached after just one rotation of the drum. The standard-equipped pressure dew point sensor continuously monitors compressed air drying quality.

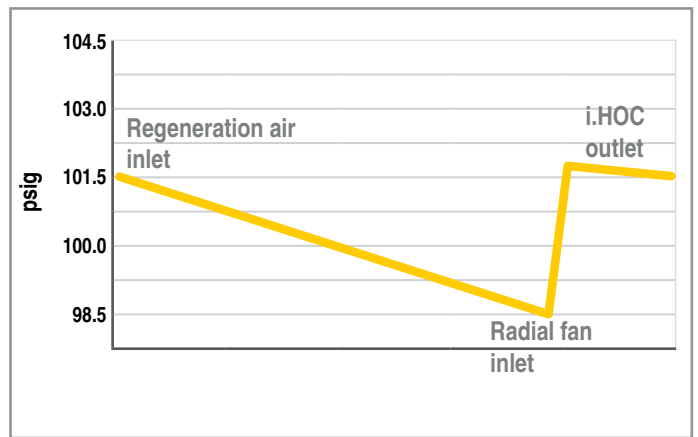

No pressure loss

The radial fan in the base of the rotation dryer equalizes drying process pressure losses as needed, thereby guaranteeing maximum pressure dew point stability and quality - the pressure at the i.HOC dryer outlet is even higher than that at the inlet.

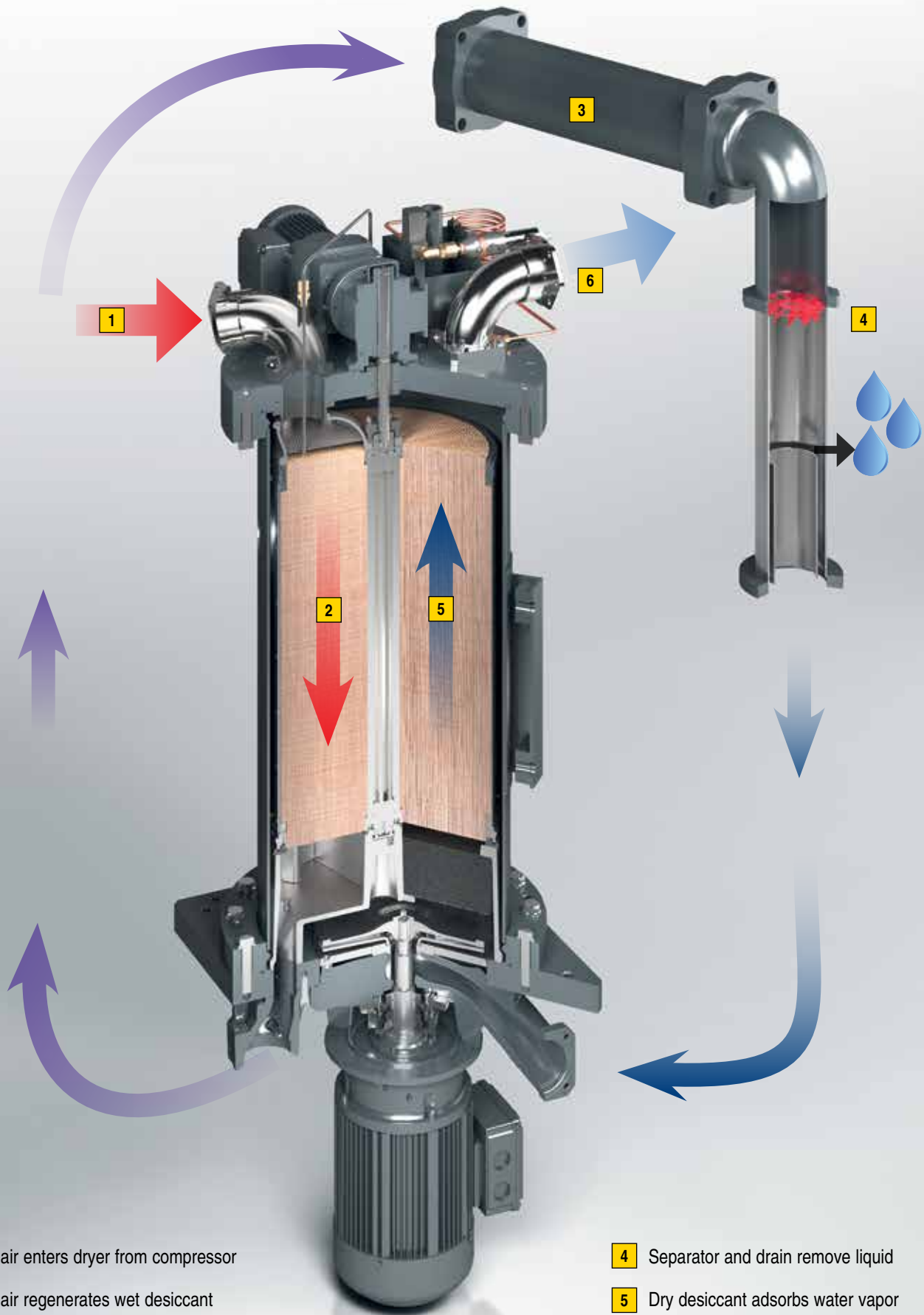

- 1** Hot air enters dryer from compressor
- 2** Hot air regenerates wet desiccant
- 3** Cooler condenses water to liquid

- 4** Separator and drain remove liquid
- 5** Dry desiccant adsorbs water vapor
- 6** Dry air exits dryer

High efficiency and low dew points



Precision drum

The silica gel desiccant is bedded in a precision-manufactured drum with exceptionally high run-out qualities. Incorrect flow within the dryer and the resulting pressure dew point fluctuations are therefore avoided.



Variable speed drum motor

Drum speed is automatically adjusted to actual compressor output, so as to regenerate the desiccant as effectively as possible. This is the key to ensuring consistently low pressure dew points.



Durable and efficient

The flow-optimized radial fan, which is integrated into the base of the dryer, efficiently compensates for pressure losses in the i.HOC's cooling path.

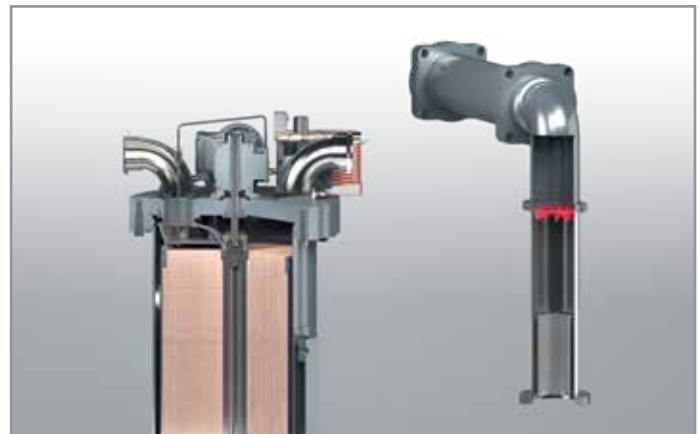

External condensate separation

The i.HOC system uses a highly efficient condensate separator downstream from the heat exchanger in the second compression stage, so as to separate the condensate formed during the regeneration process outside the dryer. This protects the drum from excess moisture.

Integrated heat recovery

Fig 1: CSG - Water-cooled version with heat recovery

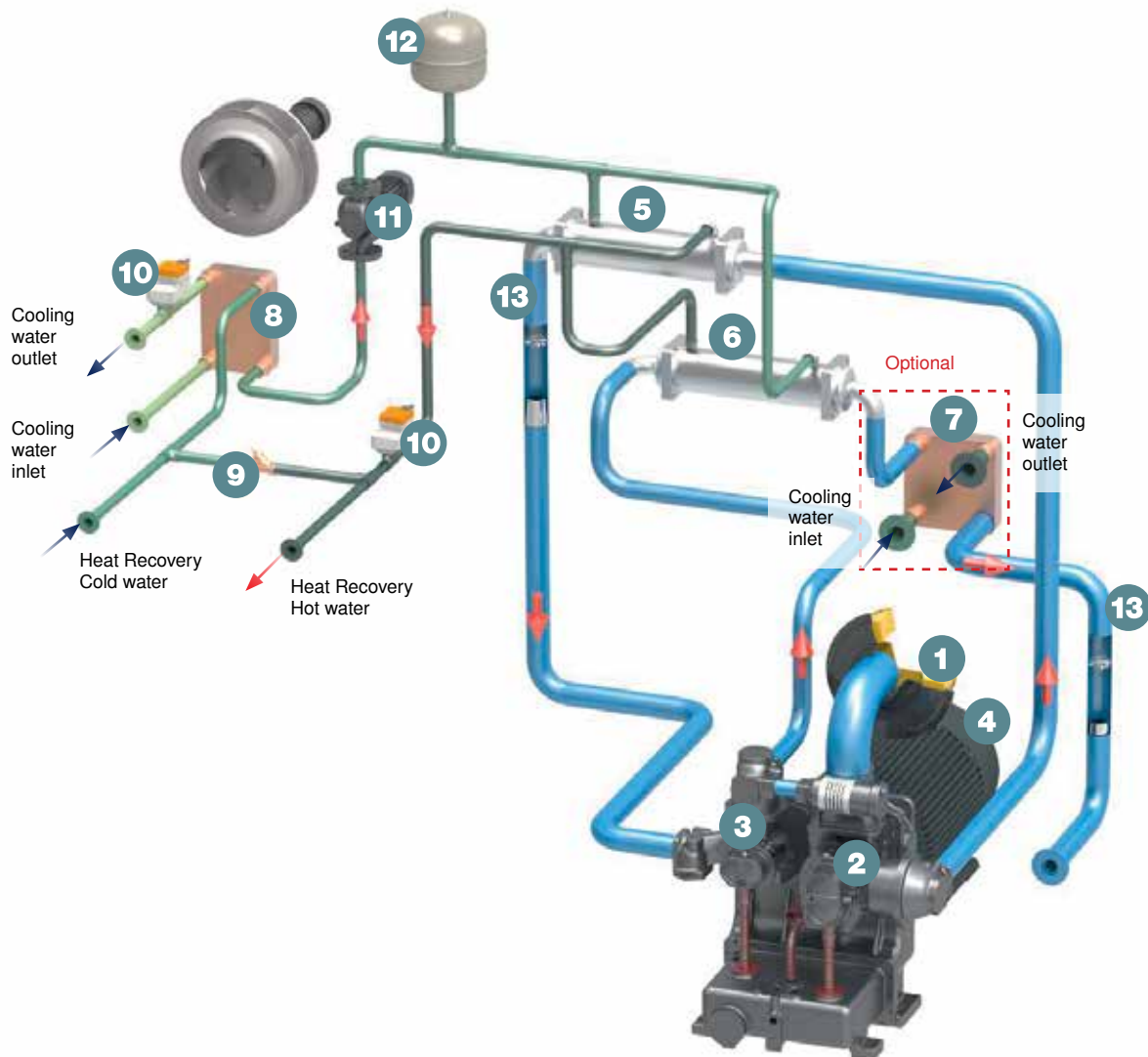

- | | |
|--|--|
| (1) Intake filter | (8) Heat exchanger (water/water) |
| (2) Low-pressure stage (stage 1) | (9) Check valve |
| (3) High-pressure stage (stage 2) | (10) Water regulating valve
(actuated by SIGMA CONTROL 2) |
| (4) Drive motor | (11) Pump |
| (5) Air cooler downstream from stage 1 (air/water) | (12) Expansion tank |
| (6) Air cooler downstream from stage 2 (air/water) | (13) Condensate separator |
| (7) Optional additional heat exchanger (air/water)
→ Version as plate-type heat exchanger | (14) Integrated i.HOC rotation dryer (in Fig 2 only) |

In two-stage oil-free compression rotary screw compressors, approximately 90% of the usable heat is processed through the two air coolers (5) and (6). The CSG features separate, high-quality heat exchangers developed specially to meet heat recovery requirements. The remaining 10% of usable heat is processed through the oil cooler and in the jacket cooling system of the compressor stages.



Fig 2: Version with rotation dryer

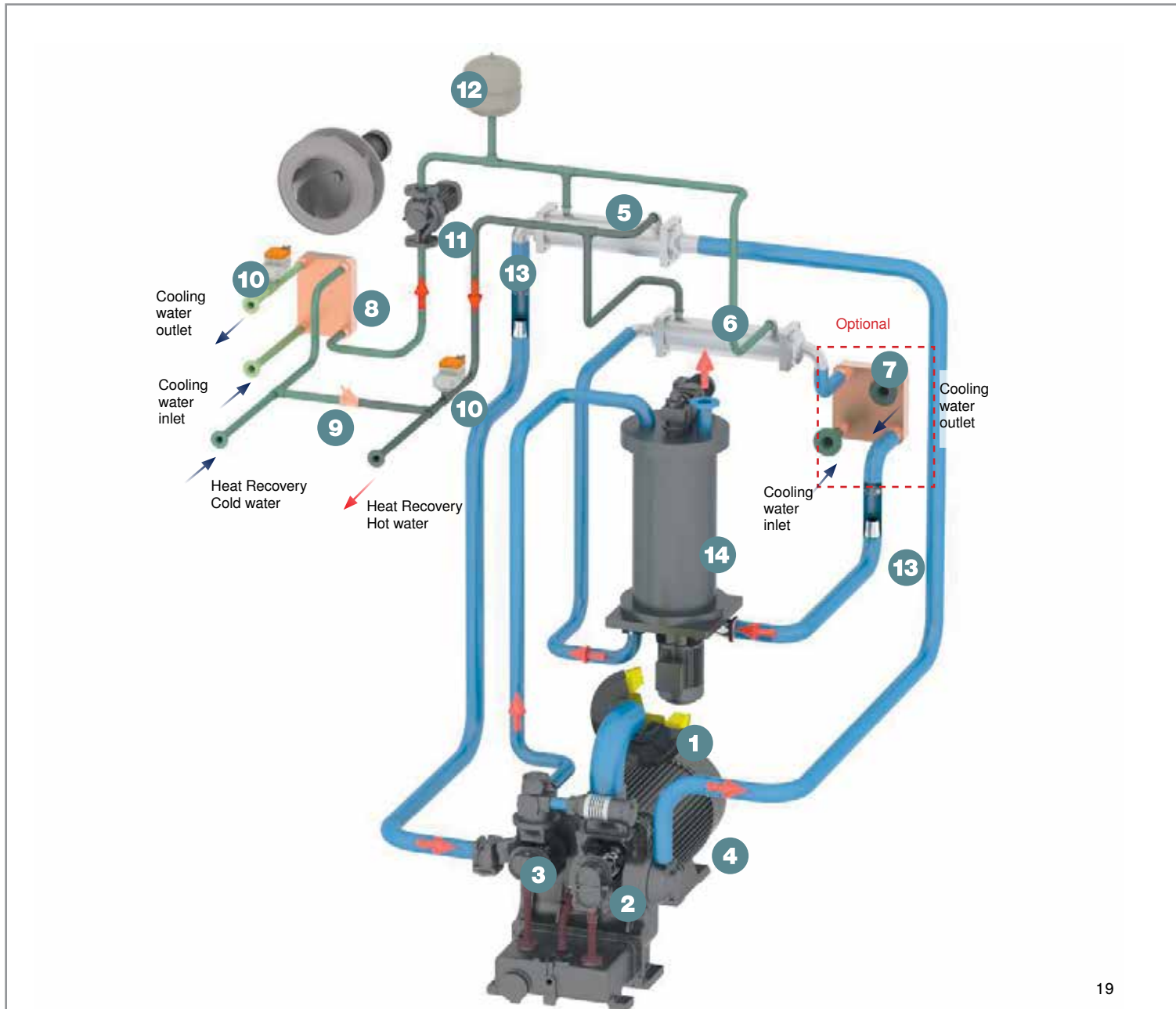

Why recover heat?

It is a simple fact that compressors convert electrical energy into heat. You can significantly reduce your energy consumption and carbon footprint by recycling waste heat from either air or water-cooled compressors.

Air-cooled compressors

Space heating with hot exhaust air

Heating made simple: Thanks to radial fans with high residual thrust, the warm exhaust air from air-cooled CSG systems can easily be ducted away to spaces that require heating - and usually without the need for additional fans.



Water-cooled compressors

Process, heating and service water

With water-cooled models, even more heat can be easily captured via the CSG's integrated heat recovery to heat water up to 195°F. There are multiple configuration options for a wide range of production or auxiliary heating applications. Costly, complex and space-intensive external infrastructure is unnecessary, and the amortization period of the heat recovery module is usually less than a year (see example calculation below).



Example amortization calculation water-cooled compressor	
Inlet temperature	68°F
Relative humidity	30%
Cooling water inlet (primary)	68°F
Cooling water outlet (primary)	155°F
Compressor power consumption CSG 150 145 psi(g)	102 kW
Heat recovery potential based on total power consumption	86%
Recoverable heat capacity	88 kW
Annual operating hours	6,000 hrs
Kilowatt hours per year	528,000 kWh
Fuel costs	\$0.10 / kWh
Annual fuel cost savings	\$52,800
Amortization period	< 1 year

Technical Specifications

Fixed Speed

Model	Pressure Range (psig)	Rated Motor Power (hp)	Air-cooled				Water-cooled									
			Capacity (acfm) ⁽¹⁾	Sound (dB(A)) ⁽²⁾	Dimensions W x D x H (in.) ⁽³⁾	Weight (lb.) ⁽⁴⁾	Capacity (acfm) ⁽¹⁾	Sound (dB(A)) ⁽²⁾	Dimensions W x D x H (in.) ⁽³⁾	Weight (lb.) ⁽⁴⁾						
CSG 60	90	50	248	70	86¾ x 60¼ x 83¾ T: 101½ x 60¼ x 83¾ i.HOC: 114¾ x 60¼ x 83¾	5512	255	66	86¾ x 60¼ x 77¾ i.HOC: 114¾ x 60¼ x 77¾	5512						
CSG 60 T ⁽⁶⁾	125		211				218									
CSG 60 i.HOC	160		184				191									
CSG 75	90	60	312	70		86¾ x 60¼ x 83¾ T: 101½ x 60¼ x 83¾ i.HOC: 114¾ x 60¼ x 83¾	5622	318		67	86¾ x 60¼ x 77¾ i.HOC: 114¾ x 60¼ x 77¾	5622				
CSG 75 T ⁽⁶⁾	125		270					277								
CSG 75 i.HOC	160		237					244								
CSG 95	90	75	368	71			86¾ x 60¼ x 83¾ T: 101½ x 60¼ x 83¾ i.HOC: 114¾ x 60¼ x 83¾	5622		374		68	86¾ x 60¼ x 77¾ i.HOC: 114¾ x 60¼ x 77¾	5622		
CSG 95 T ⁽⁶⁾	125		327							333						
CSG 95 i.HOC	160		287							293						
CSG 125	90	100	484	71				86¾ x 60¼ x 83¾ T: 101½ x 60¼ x 83¾ i.HOC: 114¾ x 60¼ x 83¾		5622		491		69	86¾ x 60¼ x 77¾ i.HOC: 114¾ x 60¼ x 77¾	5622
CSG 125 T ⁽⁶⁾	125		461									468				
CSG 125 i.HOC	160		427									433				
CSG 150	90 ⁽⁵⁾	125	563	72	86¾ x 60¼ x 83¾ T: 101½ x 60¼ x 83¾ i.HOC: 114¾ x 60¼ x 83¾				6173	571		70		86¾ x 60¼ x 77¾ i.HOC: 114¾ x 60¼ x 77¾		6173
CSG 150 T ⁽⁶⁾	125		521							528						
CSG 150 i.HOC	160		483							490						

Dimensions

Compressor W x D x H in.	With add-on refrigeration dryer W x D x H in.	i.HOC W x D x H in.
86¾ x 60¼ x 83¾	T: 101½ x 60¼ x 83¾	114¾ x 60¼ x 83¾
		

1) Flow rate complete system as per ISO 1217: 2009, Annex C/E, inlet pressure 14.5 psi (a), cooling and inlet air temperature 68°F, rel. humidity 0%

2) Sound pressure level as per ISO 2151 and basic standard ISO 9614-2, tolerance: ±3 dB(A)

3) Dimensional drawings for air-cooled and water-cooled units as well as "T" and i.HOC models are available on request from your local authorized KAESER distributor

4) Weight may vary slightly depending on airoend model

5) 90 psig not available on CSG 150 T and CSG 150 i.HOC



6) "T" models only available as air-cooled

Specifications are subject to change without notice.

SIGMA FREQUENCY CONTROL (SFC)

Model	Pressure Range (psig)	Rated Motor Power (hp)	Air-cooled				Water-cooled								
			Capacity (acfm) ⁽¹⁾ Min/Max	Sound (dB(A)) ⁽²⁾	Dimensions W x D x H (in.) ⁽³⁾	Weight (lb.) ⁽⁴⁾	Capacity (acfm) ⁽¹⁾ Min/Max	Sound (dB(A)) ⁽²⁾	Dimensions W x D x H (in.) ⁽³⁾	Weight (lb.) ⁽⁴⁾					
CSG 75 SFC	90	75	143 / 311	71	86¾ x 60¼ x 83¾ T: 101½ x 60¼ x 83¾ i.HOC: 114¾ x 60¼ x 83¾	149 / 322	68	86¾ x 60¼ x 77½ i.HOC: 114¾ x 60¼ x 77½	5512						
CSG 75 SFC T ⁽⁶⁾	125		142 / 268			174 / 352									
CSG 75 SFC i.HOC			149 / 279												
CSG 95 SFC	90	75	168 / 346	72		86¾ x 60¼ x 83¾ T: 101½ x 60¼ x 83¾ i.HOC: 114¾ x 60¼ x 83¾	174 / 352		69	86¾ x 60¼ x 77½ i.HOC: 114¾ x 60¼ x 77½	5512				
CSG 95 SFC T ⁽⁶⁾	125		167 / 334				174 / 345								
CSG 95 SFC i.HOC			160				100					166 / 302	174 / 313		
CSG 125 SFC	90	100	185 / 511	72			86¾ x 60¼ x 83¾ T: 101½ x 60¼ x 83¾ i.HOC: 114¾ x 60¼ x 83¾		192 / 524		70	86¾ x 60¼ x 77½ i.HOC: 114¾ x 60¼ x 77½	5622		
CSG 125 SFC T ⁽⁶⁾	125		184 / 464						191 / 477						
CSG 125 SFC i.HOC			160						174 / 415					182 / 427	
CSG 150 SFC	90 ⁽⁵⁾	125	185 / 584	73					86¾ x 60¼ x 83¾ T: 101½ x 60¼ x 83¾ i.HOC: 114¾ x 60¼ x 83¾		192 / 596		71	86¾ x 60¼ x 77½ i.HOC: 114¾ x 60¼ x 77½	5732
CSG 150 SFC T ⁽⁶⁾	125		184 / 531								191 / 539				
CSG 150 SFC i.HOC			160								184 / 489				

Dimensions

Compressor W x D x H in.	With add-on refrigeration dryer W x D x H in.	i.HOC W x D x H in.
86¾ x 60¼ x 83¾	101½ x 60¼ x 83¾	114¾ x 60¼ x 83¾
		

- 1) Flow rate complete system as per ISO 1217: 2009, Annex C/E, inlet pressure 14.5 psi (a), cooling and inlet air temperature 68°F, rel. humidity 0%
- 2) Sound pressure level as per ISO 2151 and basic standard ISO 9614-2, tolerance: ±3 dB(A)
- 3) Dimensional drawings for air-cooled and water-cooled units as well as "T" and i.HOC models are available on request from your local authorized KAESER distributor
- 4) Weight may vary slightly depending on airend model
- 5) 90 psig not available on CSG 150 T and CSG 150 i.HOC
- 6) "T" models only available as air-cooled

Specifications are subject to change without notice.

Options

	Model	Air-cooled	Water-cooled
Vibration measurement and motor bearing temperature monitoring (Monitoring of bearings on the motor and the compressor. Warning and fault levels are programmed in the controller.)	CSG CSG T CSG i.HOC	S	S
Automatic motor bearing lubrication (Drive motor bearings, with CSG i.HOC additionally for the fan motor bearings)	CSG CSG T CSG i.HOC	S	S
Pressure dew point measurement (Pressure dew point sensor standard on CSG i.HOC systems)	CSG i.HOC	S	S
Bolt down machine feet	CSG CSG T CSG i.HOC	●	●
Silencer, air inlet opening (Sound insulated connecting links upstream from heat exchangers)	CSG CSG T CSG i.HOC	●	—
Cooling-air filter mats (Protects the heat exchanger against heavy contamination)	CSG CSG T CSG i.HOC	●	—
Integrated heat recovery with pump (Compressor is equipped with a complete second auxiliary water system, including water pump. this protects the compressor against excessive temperatures.)	CSG CSG T CSG i.HOC	—	●
Integrated heat recovery without pump (Compressor is equipped with a second auxiliary water system, without water pump. This protects the compressor against excessive temperatures.)	CSG CSG T CSG i.HOC	—	●
Auxiliary heat exchanger downstream from stage 2 compressed air cooler (Reduces the compressed air discharge temperature in compressors with heat recovery. Improves the pressure dew point for compressors with i.HOC.)	CSG CSG T CSG i.HOC	—	●
Integrated heat exchanger downstream from i.HOC rotation dryer (Reduces the compressed air discharge temperature from the compressor in packages with integrated i.HOC.)	CSG i.HOC	●	●
Pressure dew point control (Pressure dew point measurement and controlled bypass around the stage 1 heat exchanger to improve pressure dew point as needed.)	CSG i.HOC	●	●
KAESER hot air control (Bypass around the stage 1 heat exchanger to increase compressed air temperature after leaving the 2nd stage, as needed. No heat exchanger installed downstream from the 2nd stage.)	CSG	●	●
Not available for packages with CSG i.HOC or CSG T			

● Available

— Not available

S Standard equipment

* "T" models not available water-cooled

The world is our home

As one of the world's largest compressed air systems providers and compressor manufacturers, KAESER COMPRESSORS is represented throughout the world by a comprehensive network of branches, subsidiary companies and factory trained partners.

With innovative products and services, KAESER COMPRESSORS' experienced consultants and engineers help customers to enhance their competitive edge by working in close partnership to develop progressive system concepts that continuously push the boundaries of performance and compressed air efficiency. Every KAESER customer benefits from the decades of knowledge and experience gained from hundreds of thousands of installations worldwide and over ten thousand formal compressed air system audits.

These advantages, coupled with KAESER's worldwide service organization, ensure that our compressed air products and systems deliver superior performance with maximum uptime.



Kaeser Compressors, Inc.
511 Sigma Drive
Fredericksburg, VA 22408 USA
Telephone: 540-898-5500
Toll Free: 800-777-7873
info.usa@kaeser.com

Kaeser Compressors Canada Inc.
3760 La Vérendrye Street
Boisbriand, QC J7H 1R5 CANADA
Telephone: (450) 971-1414
Toll free: (800) 477-1416
info.canada@kaeser.com

Kaeser Compresores de México S de RL de CV
Calle 2 #123
Parque Industrial Jurídica
76100 Querétaro, Qro.
Telephone: 01 (442) 218 64 48
sales.mexico@kaeser.com

Kaeser Compresores de Guatemala y Cia. Ltda.
3a calle 6-51, zona 13
Colonia Pomplona
01013-Guatemala City
Telephone: +502 2412-6000
info.guatemala@kaeser.com

www.kaeser.com